



Most advanced sensor in the SWS range reporting both WMO Table 4680 and METAR codes

Exclusive backscatter sensor gives unparalleled ability to identify frozen precipitation

Compact forward scatter design simplifies installation and integration with aviation Runway Visual Range (RVR) and METAR systems

KEY FEATURES & BENEFITS

- WMO Table 4680 and METAR present and past weather codes
- Automatic window contamination monitoring – ensures optimum accuracy whilst minimising maintenance requirements
- Wide range of visibility reporting formats including Meteorological Optical Range (MOR) and atmospheric extinction coefficient (EXCO)
- Easy integration with the ALS-2 Ambient Light Sensor – fast installation, reliable results
- 10m to 75km measurement range
- Calibration traceable to a national weather service transmissometer in accordance with ICAO standards
- 3 Years warranty

The SWS-250 Visibility and Present Weather sensor is the most advanced of the SWS series with many of the present weather reporting capabilities of Biral's flagship VPF-750 present weather sensor. The use of a backscatter receiver, exclusive to Biral sensors, significantly improves the accuracy of present weather reporting and allows a wider range of precipitation types to be identified with confidence. The ability to accurately distinguish frozen from non-frozen precipitation can be of significant importance in aviation applications and national weather service monitoring networks.

Visibility Measurement

The measurement of visibility by forward scatter as used by the SWS-250 is now widely accepted and seen as having significant advantages over more traditional techniques such as the use of transmissometers. Whilst transmissometers have the advantage of direct visibility measurement they are expensive to both acquire and maintain, whilst the limited measurement range restricts their use in some applications. Forward scatter sensors by contrast are compact, considerably less expensive and require less maintenance. The measurement range can extend from 10m to 75km and the forward scatter measurement technique is approved by ICAO for use in aviation applications.

The calibration of the SWS sensor family was undertaken in accordance with the recommendations of ICAO 9328 and is

traceable to a national weather service transmissometer. The SWS-250 reports visibility as both Meteorological Optical Range (MOR) and Extinction Coefficient (EXCO).

Present Weather Measurement

The determination of precipitation type in a forward scatter sensor is made by observing the intensity of scattered light and the transit time for each precipitation particle. These parameters are used to estimate the particle size and determine if it is liquid or frozen using well established relationships, unfortunately in anything other than still conditions the relationships become unreliable, resulting in poor classification accuracy. Biral sensors are the only ones to solve this problem through the use of a backscatter receiver. The ratio of forward to backscatter is significantly different for liquid and frozen particles, allowing the SWS-250 to report the correct precipitation code reliably even in the most challenging conditions.

The SWS-250 has the added benefit of enhanced present weather classification algorithms enabling the sensor to report a wider range of precipitation types than any other sensor in the SWS family. The ability to accurately report precipitation type, especially the ability to discriminate liquid from frozen precipitation, can be very important in both aviation and national weather service monitoring network applications.



Raindrop

or ...



Snowflake

Biral's backscatter receiver reliably determines if the particle is liquid or frozen, reporting the correct precipitation code even in the most challenging conditions.

Applications

National Observation Networks

Whilst the models used for forecasting continue to improve there remains a need for accurate measurement of current weather conditions to provide the model's input. Improvements to forecast accuracy can also be gained by increasing the number of monitoring sites but there is always a trade-off



The SWS-250 is ideally suited to provide accurate measurement of raw data for forecasting models.

between forecast quality and cost. The SWS-250 is ideally suited to this type of application due to the accuracy of measurement, the wide range of present weather conditions reported and the cost effective design.

Aviation

In aviation there is a trend towards increasing both safety and capacity at aerodromes which can require the installation of visibility and present sensors on runways and increasingly along taxi ways. The SWS-250 meets or exceeds all international aviation specifications for visibility measurement and present weather reporting whilst offering an affordable solution for both acquisition and cost of ownership.



Suitable for a range of applications.

The SWS-250 is suited to many other applications including research and road weather monitoring where the costs of deploying a dense sensor network can have a significant impact on the choice of sensor.

Interfacing, Connectivity and Cost of Ownership

The SWS sensor family is designed for easy installation by a single person and has an interface which simplifies system integration. The ASCII text data message is transmitted at user defined time periods or in response to a polled request. The standard data message provides MOR and EXCO along with present weather codes according to both WMO Table 4680 and METAR standards. An optional interface to the ALS-2 Ambient Light Sensor simplifies use in aviation applications where both METAR and RVR information is required. The ALS-2 Ambient Light Sensor data is appended to the standard sensor data message simplifying both installation and data processing.



Biral's ALS-2 Ambient Light Sensor

Advanced Diagnostics

To keep track of the operational status of the sensor, abbreviated self-test information is included in every data message with a full self-test report available on request. Self-test features include window contamination monitoring which automatically corrects the output data and provides two stage warnings allowing maintenance to be

performed most efficiently. Calibration checks and recalibration are simple and quickly accomplished in the field by a single person. The need for such procedures is limited however as the stability of the light source and receiver circuitry is such that recalibration intervals are typically measured in years.

The SWS-250 is DC powered with the capability to accept separate supplies for sensor electronics and the high power hood heaters. Hood heating is only required in regions where blowing snow is encountered. To conserve power the heaters are fully automatic and only operate when the temperature drops below 4°C.

Sensor Configuration Information

For a detailed explanation of the configuration options please refer to the table below.

25 – SWS-250 Sensor

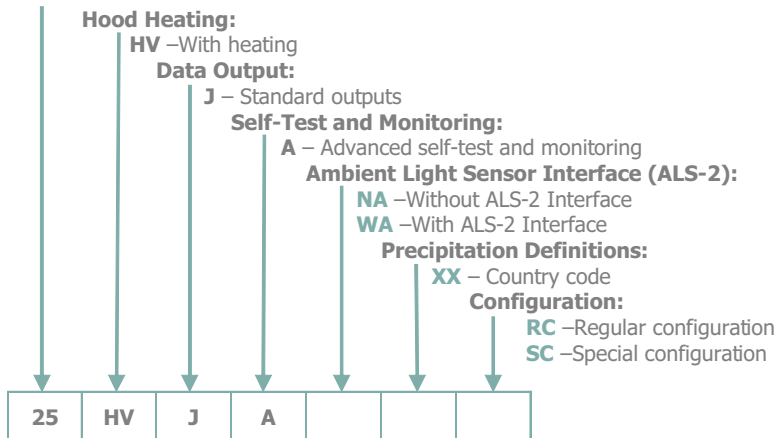

Example: 25.HV.J.A.NA.UK.RC (Please use this code when ordering your sensor).

Configuration Options Explained

Option	Description
Heating Options	Heated hoods are available to stop snow from accumulating around the optical windows. The sensor is fitted with hood heating as standard. No other option available. Option HV : Hood heating included
Data Output	The sensor has RS232, RS422 and RS485 serial output capabilities. No other options are available. Option J : Standard serial outputs
Self-Test & Monitoring	The sensor is provided with Advanced Self-Test capability. Advanced self-test capability provides monitoring of all the essential sensor functions, contamination of the transmitter window, plus receiver winder contamination monitoring and receiver sensitivity monitoring. Advanced self-test capability provides greater measurement confidence in applications where different levels of contamination may occur on the sensor windows, for example where strong or gusty winds are experienced. No other options are available. Option A : Advanced Self-Test
ALS-2 Interface	The sensor may be configured to allow direct connection of the ALS-2 Ambient Light Sensor. The Ambient Light Sensor is typically used in airport applications where Runway Visual Range must be calculated. Option NA : Without Ambient Light Sensor Interface Option WA : With Ambient Light Sensor Interface
Precipitation Codes	Biral present weather sensors report precipitation and visibility according to predefined intensity values. As no universal definition for intensity values is available, sensors can be supplied configured to the requirements of a range of countries or the customer may supply their own definitions. Where custom definitions are required please complete a Custom Present Weather Definition Form, available from our Sales Department (enquiries@biral.com). For a full list of the currently available country codes please refer to the Present Weather Sensor Country Code List, available from our Sales Department (enquiries@biral.com) or as a download from the SWS-200 product page of our website (www.biral.com).
Configuration	Reserved for customer specific configurations. Option RC : No customer specific configuration Option SC : Special customer specific configuration

SWS-250

Visibility & Present Weather Sensor Specifications



Visibility & Present Weather Measurement

Measures	Visibility, present and past weather	
Output	Serial data	
Range (visibility)	Default 10m to 75km	
Measurement Error	≤ 4.5% at 600m, ≤ 5.1% at 2km, ≤ 20% at 30km	≤ 5.0% at 1,500m ≤ 12.5% at 15km
Measurement principle	Forward scatter meter with 39° to 51° angle	
Precipitation detection threshold	Rain: 0.015mm/hr Snow: 0.0015mm/hr	(0.0006in/hr) (0.00006in/hr)
Maximum rain rate	~ 500mm/hr	(20in/hr)
Rain intensity accuracy	≤ 15%	

Outputs and Reports

Output rate (seconds)	10 to 300 (selectable)
Serial outputs	RS232, RS422 and RS485
WMO Codes	39 from table 4680
METAR Codes	34 present and past weather

Power Requirements

Sensor power	9-36 Vdc
Hood heating power	24 Vac or Vdc
Basic sensor	3.5 W
Window heaters	2.5 W
Hood heaters	36 W

Additional Features

Hood heaters	Fitted as standard
Window heaters	Fitted as standard
Window contamination Monitoring	Fitted as standard to all sensor head windows

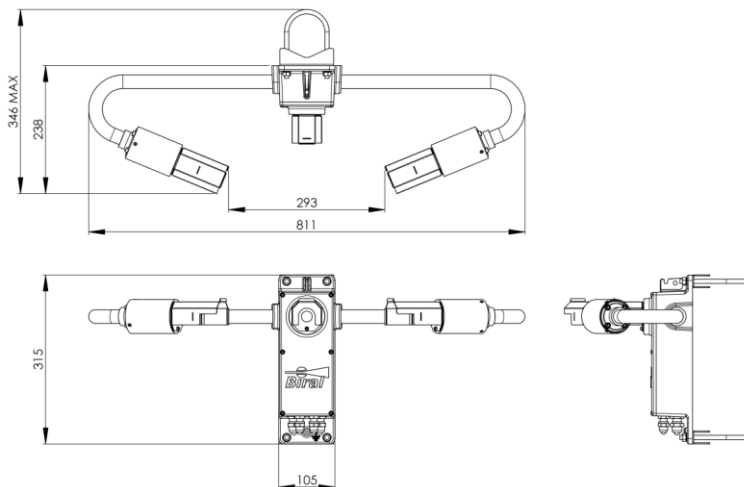

Dimensions in mm

Environmental

Operating temperature	-40°C to +60°C
Operating humidity	0 – 100% RH
Protection rating	IP66/IP67

Certification & Compliance

CE certified
EMC compliance with EN61326-1997, 1998, 2001
RoHS and WEEE compliant

Physical

Material	Powder paint coated aluminium
Weight (incl. mounting kit)	4.5kg
Length	0.81m
Warranty	3 Years
Lifetime	>10 Years

Maintenance

Self-test capability	As standard
User confidence check	6 months recommended
Window cleaning	Automatic compensation and warnings
Field calibration	With optional calibration kit

Included with Sensor

The SWS sensor is delivered in sturdy recyclable foam filled packaging with:

- Pole mounting kit (2 x U-bolt and saddles)
- User manual and calibration certificates

Accessories – Optional

00.SWS.CABLE-D	SWS Series Data Cable per metre
00.SWS.CABLE-P	SWS Series Power Cable per metre
SWS.CAL	SWS Series Calibration Kit
SWS.CASE	SWS Series Transit Case
SWS.SK200	SWS 200 Spares Kit
SWS.WTY250	1 Year Extended Warranty
PW.CODE	User defined precipitation definitions. Per definition set
PW.MAINS	Mains Power Adaptor

Specifications are subject to review and change without notice. E&OE.